

IOTA

ENGINEERING, L.L.C.

P.O. BOX 11846 TUCSON, AZ 85734
 (520) 294-3292 • FAX (520) 741-2837
www.iotaengineering.com

220VAC DLS SERIES POWER CONVERTER/CHARGER

OWNER'S MANUAL

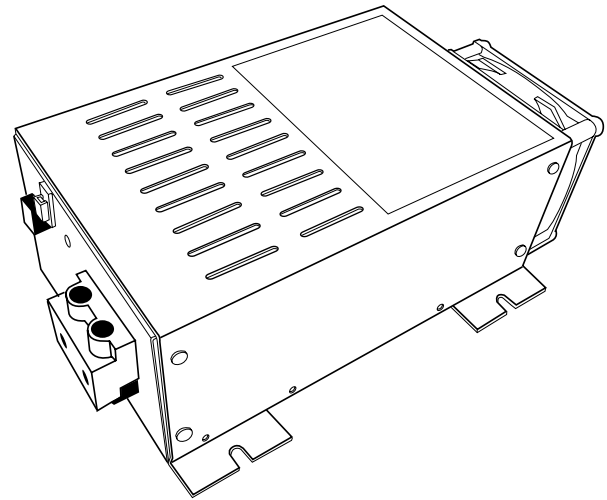

The DLS series power converter/battery charger from IOTA Engineering converts 220 volts AC to volts DC. As a power supply, its tightly controlled regulation allows the user to operate a 12 volt nominal load up to the converter's rated output current (refer to specification chart for input/output ratings). As a battery charger, the converter will maintain the battery, delivering its full-rated current when the battery capacity falls sufficiently low. The voltage is set to deliver its maximum current for the necessary period of time that minimizes undue stress to the battery caused by heating of its cells. This helps to ensure the longest possible life of the battery. Over time, as the battery nears its full capacity, the converter will float-charge the battery to prevent self-discharge of its cells.

SPECIFICATION CHART

	DLS-220-30	DLS-220-45	DLS-220-55	DLS-220-75
DC Output Voltage (No Load) approx.	13.6V (DC)	13.6V (DC)	13.6V (DC)	13.6V (DC)
Output Voltage Tolerance (No Load)	+ or - .7%	+ or - .7%	+ or - .7%	+ or - .7%
Output Amperage, Max Continuous	30 Amps	45 Amps	55 Amps	75 Amps
Output Voltage (Full Load) approx.	>13.4V (DC)	>13.4V (DC)	>13.4V (DC)	>13.4V (DC)
Maximum Power Output, Continuous	400 Watts	600 Watts	740 Watts	1000 Watts
Ripple and Noise	<50mV rms	<50mV rms	<50mV rms	<100mV rms
Input Voltage Range	200-240VAC	200-240VAC	200-240VAC	200-240VAC
Input Voltage Frequency	47-63	47-63	47-63	47-63
Maximum AC Current (@ 216 VAC)	3.5 Amps	5.5 Amps	7 Amps	8.5 Amps
Typical Efficiency	>80%	>80%	>80%	>80%
Max Inrush Current, Single Cycle	15 Amps	20 Amps	20 Amps	50 Amps
Short Circuit Protection	YES	YES	YES	YES
Overload Protection	>100%	>100%	>100%	>100%
Line Regulation	100mV rms	100mV rms	100mV rms	100mV rms
Load Regulation	<1.5%	<1.5%	<1.5%	<1.5%
Fan Control*	PROPORTIONAL	PROPORTIONAL	PROPORTIONAL	PROPORTIONAL
Thermal Protection	YES	YES	YES	YES
Working Temperature Range	0 - 40C	0 - 40C	0 - 40C	0 - 40C
Storage Temperature	-20 to 80C	-20 to 80C	-20 to 80C	-20 to 80C
Withstand Voltage	1240V @ leads	1240V @ leads	1240V @ leads	1240V @ leads
Dimensions**	9.7" x 6.7" x 3.4"	9.7" x 6.7" x 3.4"	9.7" x 6.7" x 3.4"	13" x 6.5" x 3.4"
Weight	5.0 lbs	5.0 lbs	5.0 lbs	7.8 lbs

PROTECTION FEATURES

The DLS series power converter/battery charger is designed with high quality components to help ensure years of continuous use. The DLS series is protected by multiple protection features for a long, trouble-free life.

1) *Reverse Battery Polarity Protection.* 2) *Brown-Out Input Protection.* 3) *Over-Current Protection* - cycle by cycle peak limiting as well as rated current limiting to maximize the life of the converter. 4) *Over-Temperature Protection.* In addition, it is designed with a unique "proportional" fan control circuit. Fan speed is directly proportional to the converter's internal ambient temperature. This enables the fan to turn on and off very slowly, minimizing unwanted fan-starting noise.

WARRANTY

The DLS series power converter/battery charger is warranted from defects in materials or workmanship for two years from date of retail purchase, and limits the remedies to repair or replacement. This warranty is valid only in the continental United States and Canada. For complete warranty details, contact Customer Service or visit www.iotaengineering.com

Distributed By:

INSTALLATION GUIDELINES

There are no components within the DLS unit that, in their normal operation, produce arcs or sparks. However, all electronic devices have some potential for generating sparks in the event of failure. Therefore, never install this device in the same compartment with flammable items such as gasoline or batteries.

MOUNTING LOCATION

The DLS battery charger/power supply can be mounted in any position within an enclosed or interior compartment. Provide sufficient air space to allow unrestricted airflow in and around the unit.

DLS INSTALLATION

Disconnect the positive side of the battery before installation. Connect the positive (red) and negative (black) terminal lugs to battery or load. Always use the proper size wire based on the amperage of the converter and the battery. When connecting to a battery, a breaker should be installed within 18" of the battery, connecting the battery positive to the line side of the breaker, and the DLS to the load side. Connect "Chassis Bonding Lug" on the DLS to vehicle chassis or other grounding source.

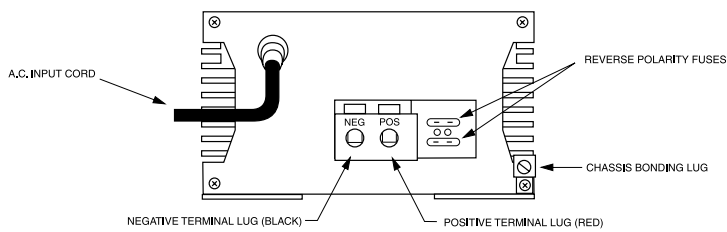

DLS-220-75

240 VOLT A.C. INPUT

The unit is equipped with a three-prong A.C. input cord for connection to the 220VAC power source. The cord is rated 250VAC, and is 3 feet long from the input side of the unit.

REVERSE POLARITY FUSES

The DLS Battery Charger/Power Supply is protected against reverse polarity on the DC output. If a battery or the DLS is hooked up incorrectly, the fuses will blow and can be easily replaced. Always use the same size and style fuse that came with the converter. To change the fuses, use a screwdriver to loosen the screws and remove the fuses. Always replace the fuses with the same type and rating. After inserting the new fuses, tighten the screws firmly.

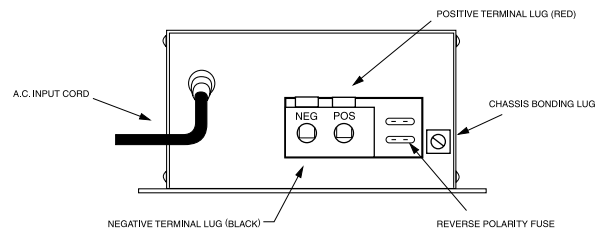

MODELS DLS-220-30, DLS-220-45, DLS-220-55

CHARGE CONTROL

TWO-STEP VOLTAGE JACK

The two-step voltage jack (located on the top of the DLS on the fan-end of the unit) allows switching from a long-term float voltage to an increased quick-charge voltage. When the included dual voltage plug is inserted in the jack*, the voltage increases for faster charging. When the plug is removed, the voltage drops to rated nominal voltage to reduce battery water loss. **WARNING: To avoid battery damage, remove the Dual Voltage Plug when quick-charging is complete.** NOTE: If the DLS is equipped with an internal IQ4 smart charger, two-step charging is not needed and the Dual Voltage Jack is disabled.

*Location of the Dual Voltage Jack may vary depending on model.

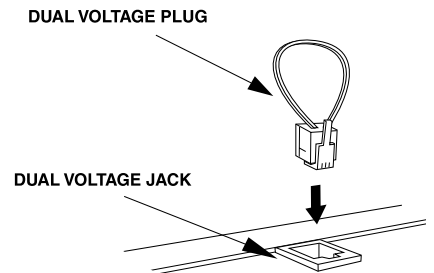

THE IQ4 LED INDICATOR

(ONLY ON DLS MODELS WITH INTERNAL IQ4)

DLS Models with an internal IQ4 smart-charger give the user the benefit of automatic Bulk, Absorption, and Float stage charging. This increases the charging capacity of the DLS charger, decreases charge times and insures proper and safe battery charging without over-charging. The green LED on the fan end of the DLS will indicate which charging phase the DLS unit is currently in. When the unit is first activated, the LED will flash as it reads the number of cells in the battery. The unit will then proceed directly to the Bulk charging or Float charging phase depending on the charge status of the battery. Use the LED CODE TABLE for reference when checking the LED. Units that do not have an internal IQ4 smart-charger can easily install an external IQ4 that plugs into the available Dual Voltage Jack. Contact Customer Service for more information.

LED CODE TABLE

CELL INDICATION		
6 FLASHES	12V Battery (6 cells)	
12 FLASHES	24V Battery (12 cells)	
18 FLASHES	36V Battery (18 cells)	
24 FLASHES	48V Battery (24 cells)	
CHARGE PHASE	LED STATUS	VOLTAGE RATE
FLOAT	ON	2.26 PER CELL
ABSORPTION	SLOW FLASHING	2.36 PER CELL
BULK	RAPID FLASHING	2.46 PER CELL